

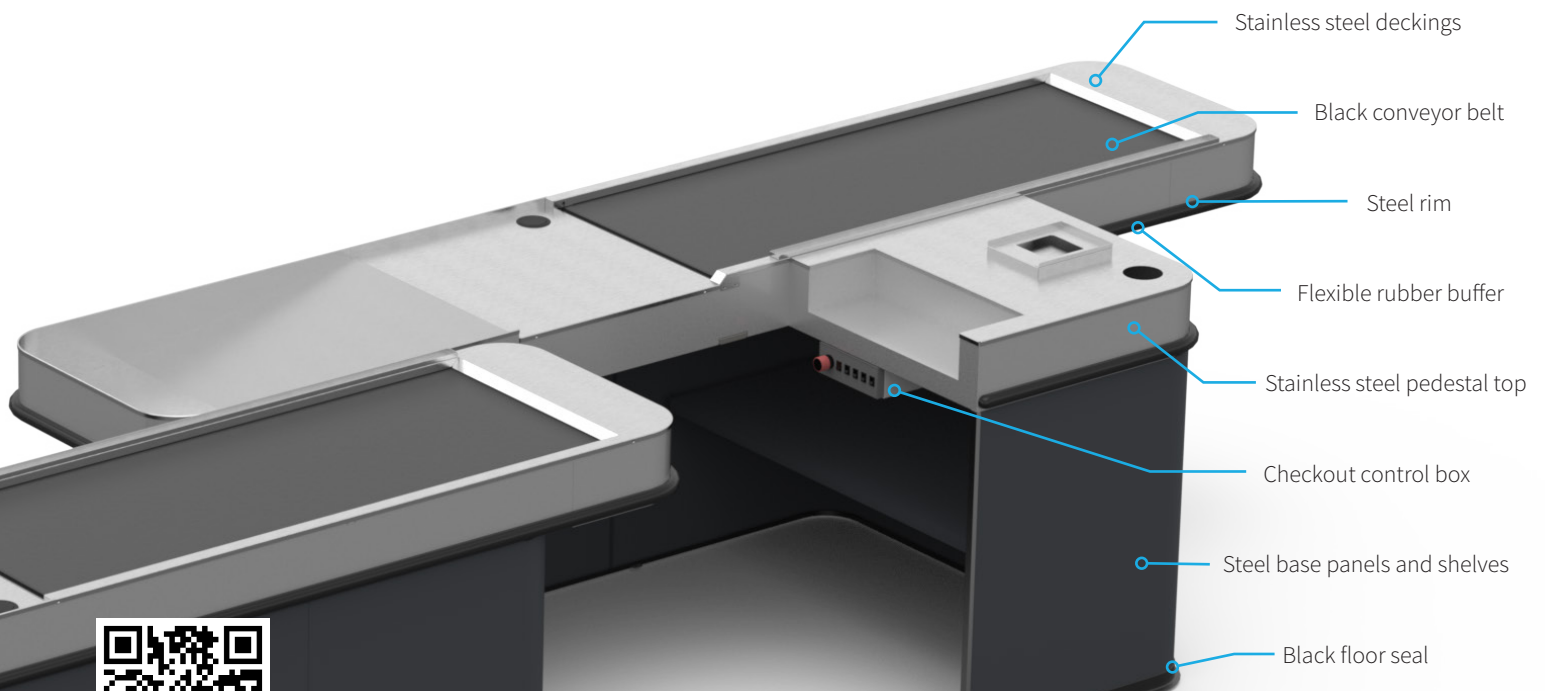

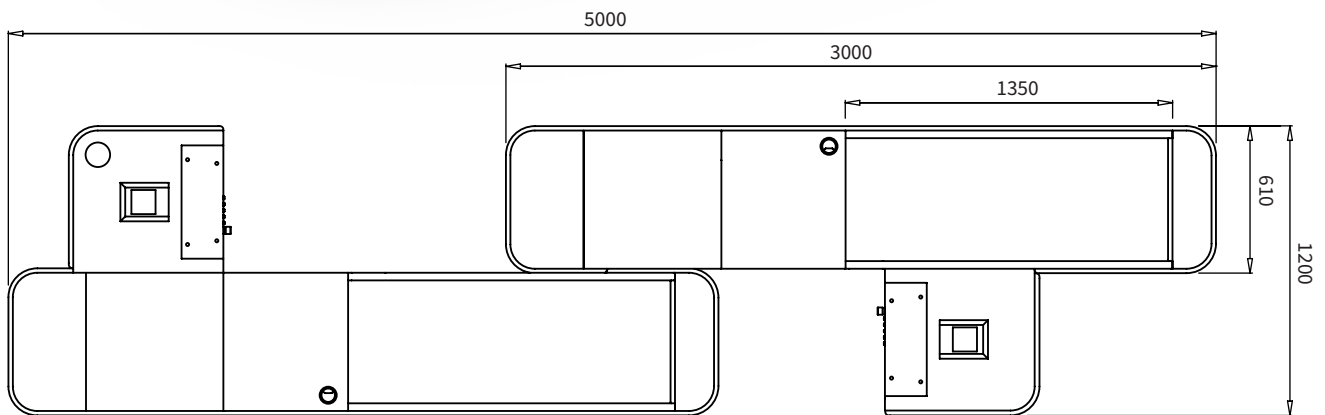

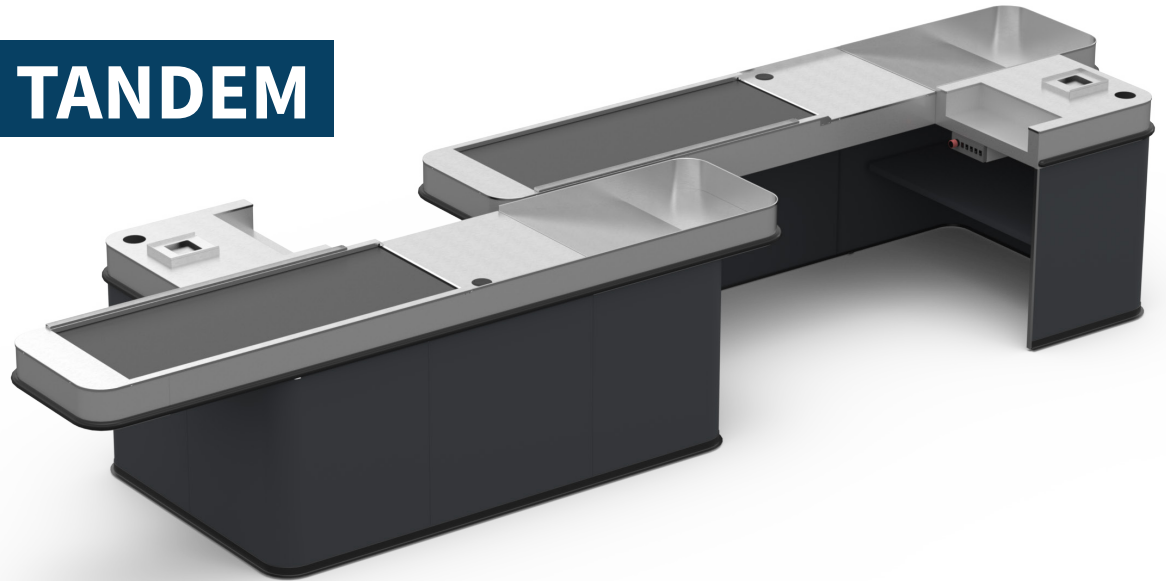

CHECKOUT

**BELTED TANDEM**



**COLOURS**

-  Cream  
RAL9001
-  Pure White  
RAL9010
-  Light Ivory  
RAL1015
-  White Aluminium  
RAL9006
-  Grey Aluminium  
RAL9007
-  Inver Grey Metallic  
EP 909384 SM
-  Slate Grey  
RAL7015
-  Umbra Grey  
RAL7022

*Other colours may be requested subject to availability*

**ADDITIONAL ACCESSORIES**



Alarmed or Non-Alarmed Gate



Retractable Webbing Barrier



Chain with No Entry Disk



Additional Sockets

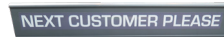

Next Customer Bars



Foot Rest



Operator Chair



Operator Stool



Call Bell



Chip & Pin Reader Holder



POS Post



Counter Cache

**OPTIONAL MANUFACTURED EXTRAS**

Overhead service pole (if required)

Configurable decking area for EPOS requirements

Acrylic screens available in two standard heights: 350mm and 600mm

Free standing merchandising unit with interchangeable shelving solutions

