

CHECKOUT

NARROW SINGLE LANE

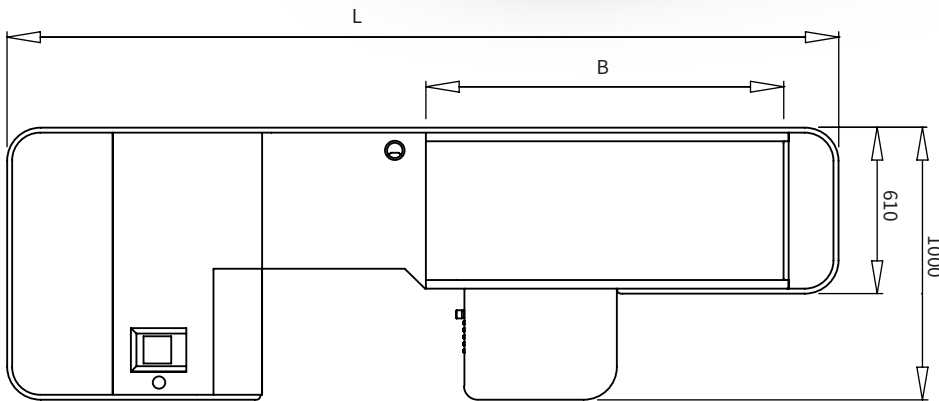

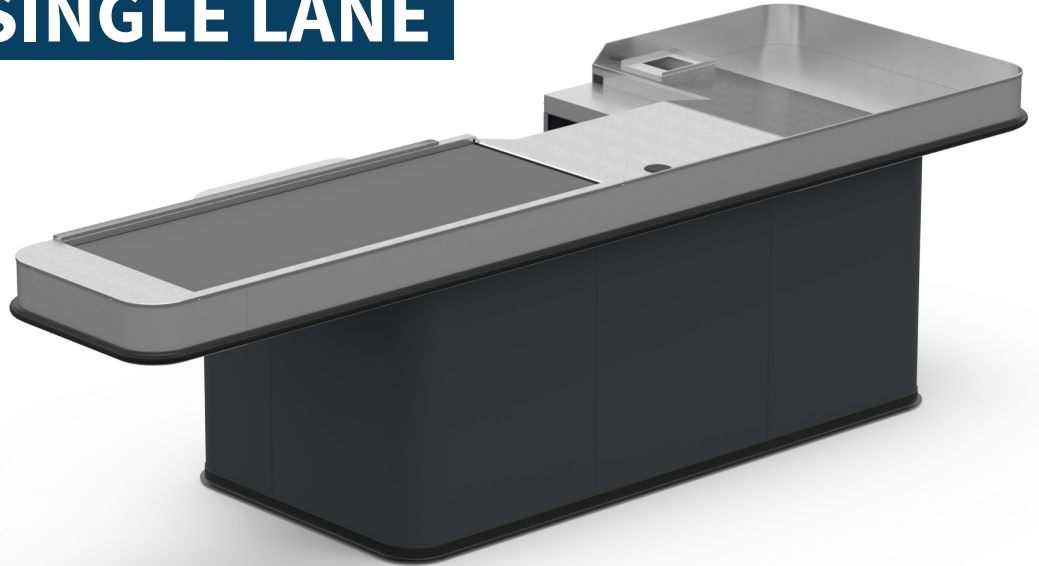

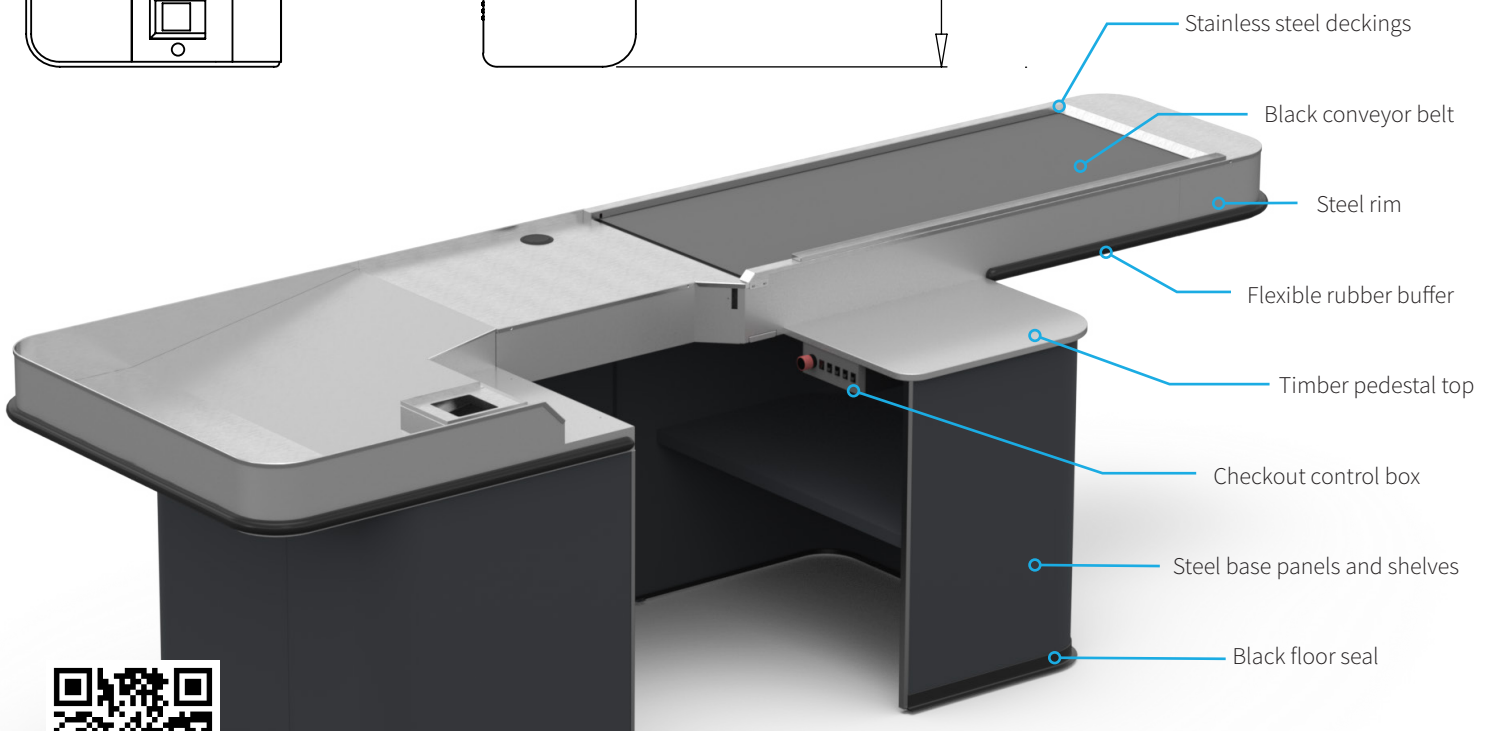

Available in lengths of 2.5m, 2.7m and 3m

L (Checkout Length)	B (Belt Length)
2500	800
2700	1000
3000	1300



COLOURS

-  Cream
RAL9001
-  Pure White
RAL9010
-  Light Ivory
RAL1015
-  White Aluminium
RAL9006
-  Grey Aluminium
RAL9007
-  Inver Grey Metallic
EP 909384 SM
-  Slate Grey
RAL7015
-  Umbra Grey
RAL7022

Other colours may be requested subject to availability

ADDITIONAL ACCESSORIES



Alarmed or Non-Alarmed Gate



Retractable Webbing Barrier



Chain with No Entry Disk



Additional Sockets

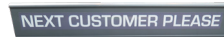

Next Customer Bars



Foot Rest



Operator Chair



Operator Stool



Call Bell



Chip & Pin Reader Holder



POS Post



Counter Cache

OPTIONAL MANUFACTURED EXTRAS

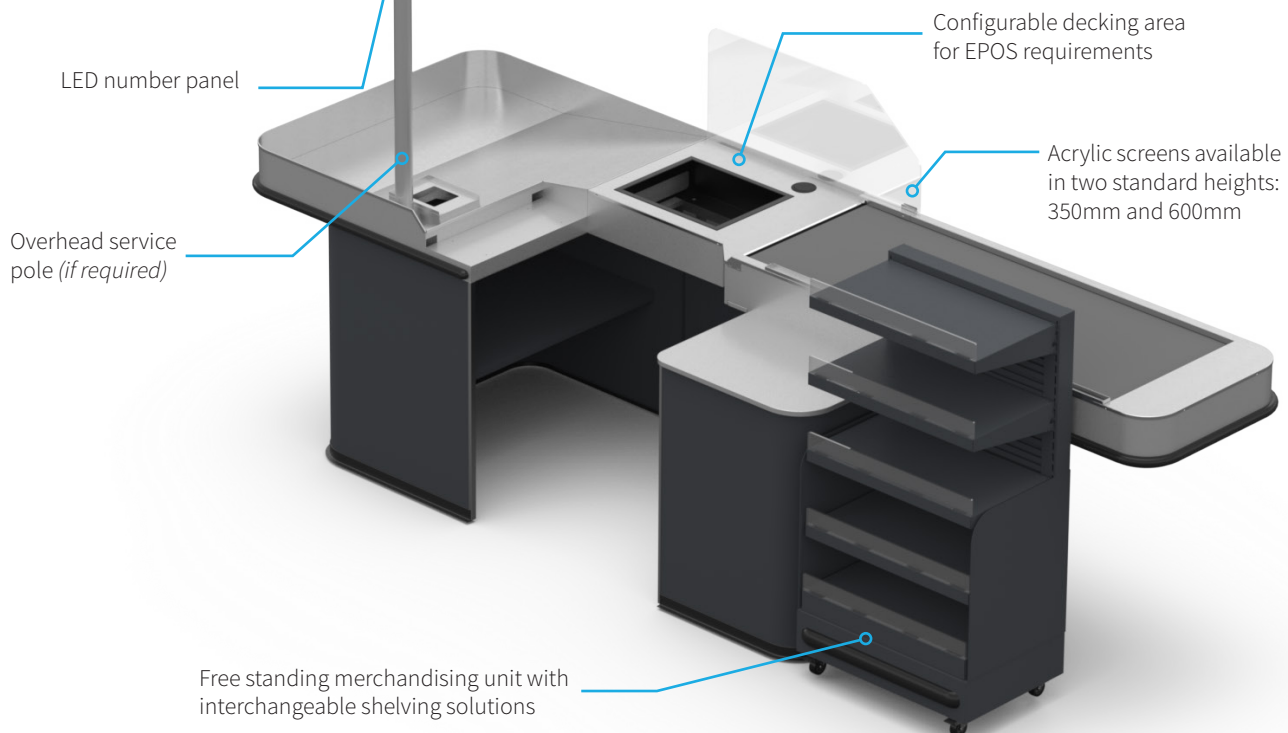

LED number panel

Overhead service pole (if required)

Configurable decking area for EPOS requirements

Acrylic screens available in two standard heights: 350mm and 600mm

Free standing merchandising unit with interchangeable shelving solutions

